

COMBUSTION AIR

Minnesota Department of Commerce Energy Information Center

The fuel-burning appliances in your home need a reliable supply of outside air to work properly. Your furnace, water heater, and other flame producing devices such as fireplaces and wood stoves use large amounts of air in the combustion process. To ensure safe and efficient operation, that air must constantly be replaced while the appliances are operating.

This replacement air is commonly called “combustion air” and its importance cannot be overemphasized. Without enough combustion air, your house can quickly become polluted with unhealthy gases, including deadly carbon monoxide (CO). Carbon monoxide is odorless, colorless, and highly poisonous.

No special means of supplying combustion air is provided in most older homes – the needed air was simply assumed to flow in through leaks in the structure. We realize now, however, that the air in our homes is dynamic. Factors such as temperature differences between indoors and outdoors and outdoor wind speeds affect air flow, and therefore it is not safe to rely on building air leakage to provide sufficient combustion air.

The Minnesota building code requires that all new homes be built with a special duct that brings outside air directly to the heating system. This requirement makes it less likely that there will be a shortage of combustion air, but it does not guarantee it. Other fuel-burning appliances such as wood stoves, fireplaces, and water heaters need combustion air, and bath and kitchen exhaust fans affect the availability of combustion air.

What causes dangerous combustion air problems?

Most furnaces, wood stoves, and fireplaces use a natural draft; the hot gases produced by the fire

rise up the chimney without mechanical assistance. This natural draft up the chimney creates a slight vacuum, which draws in air through small holes and cracks in the house, or through the combustion air duct (Figure 1). Serious problems occur when this natural flow of combustion air and exhaust gases is disrupted.

In general, combustion air problems such as backdrafting of gases occur when fuel-burning appliances demand more air than the house can supply through normal air leakage. Here is an example:

A fire is burning in the fireplace, which uses room air for combustion. The strong natural draft of the fireplace sends the combustion products up the chimney; because air is going up the chimney a vacuum is created in the house. Because it is cold outside, windows and doors are shut. Eventually the furnace comes on. The natural tendency of the hot combustion gases is to rise, but the strong suction caused by the fireplace draft pulls air down the furnace flue and combustion gases spill out of the draft hood and remain in the house. This is called “backdrafting.” The backdraft hinders the furnace exhaust, and the combustion gases can produce increasing amounts of carbon monoxide and other potentially dangerous gases. (see also *Wood Heat*)

Wood fires are not the only cause of backdrafting. Although combustion air problems are more like-



How to test for combustion air

Outside combustion air supplies for the furnace

Outside combustion air supplies for fireplaces, wood stoves

Related Guides:

- Wood Heat
- Indoor Ventilation
- Home Heating
- Home Cooling
- House Diagnostics

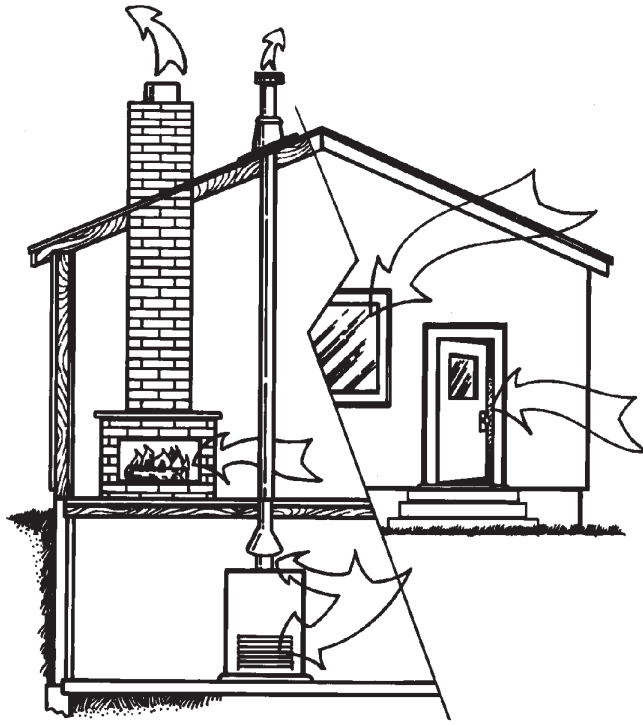

Combustion air circulation

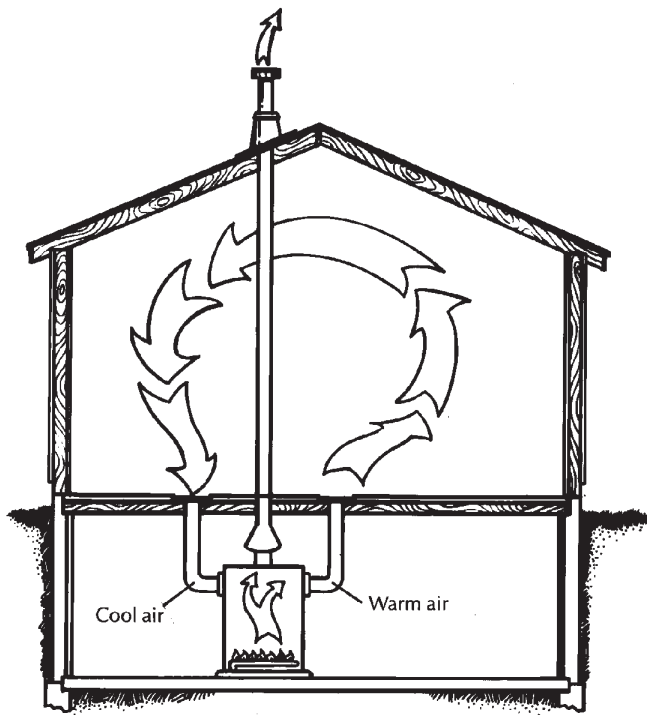

Figure 1.

ly to occur when there is an open wood fire, they are not limited to situations in which there is a wood fire. Clothes dryers, gas stoves, gas or oil water heaters, and bathroom and kitchen or range exhaust fans all make considerable demands on the air supply.

As noted above, combustion air problems can occur in any home, even older homes which were once assumed to have enough air leaks to provide outside air for combustion. Any number of home improvement or weatherization measures may increase the potential for backdrafting: for example, making our homes more comfortable and energy efficient by tightening up air leaks, adding insulation, or replacing windows. So, too, does the recent consumer trend of installing professional cooking appliances with built-in high-volume exhaust fans. These fan/exhaust systems are powerful and often remove more air from the home than what can be supplied through leaks or passive openings. It is extremely important to remember that any time we take these or other measures that affect air pressure in the home, care must be taken to provide replacement air.

How do you know if you have a combustion air problem?

You can easily check for combustion air by performing a simple draft hood test. The draft hood is an opening in the vent pipe above the furnace or water heater that allows room air to enter the venting system. It is usually a hood-like device in the pipe just above the furnace (Figure 2), or an opening near the top of the furnace (Figure 3).

The test shows if air is being pulled into the draft hood, which means the furnace is venting properly. It is done by holding a smoking object (such as an incense stick) near the hood while the furnace burner is on and watching to see if the smoke is drawn into the hood (Figure 4). If it is blown away from the hood, combustion gases are not going up the flue as they should.

You must perform the draft hood test at least twice. If you have a fireplace or wood-burning stove, you need to do it a third time. The tests should be performed on a mild day with very little or no wind. It is important to remember that the draft hood test is a "snapshot" of air performance in your home at one particular moment. A

change in wind speed or direction, or an open window, might change the result. It is recommended that you perform the test at least a couple of times over the heating season.

Test 1. The first test is simply to see if the flue is clear of obstructions. Turn on the furnace and wait a minute for the draft to stabilize. Hold the smoke source two inches from the draft hood opening. If the smoke is drawn in, your flue is clear. If it is blown away from the hood, it is essential that you check the flue for obstructions before operating the furnace. Call a heating professional.

Test 2. To perform the second test, wait about an hour or so to let the flue cool. Close all doors, windows, and fireplace and wood stove dampers. Make sure all storm doors and storm windows are in place and shut. Turn on all exhausting devices, such as kitchen and bathroom exhaust fans, clothes dryers (gas or electric), and all vented gas or oil appliances, such as water heaters. You may have to turn on a hot water tap to get the water heater to come on. Open any doors between the furnace and any exhausting device. Then turn on the furnace, wait a minute for the draft to stabilize, and repeat Test 1.

If the smoke is not drawn up the draft hood, you need to bring additional air into the house immediately. Open a window in the furnace room or

open other basement windows or doors to the outside and leave them open until you can provide a permanent combustion air supply.

Test 3. If you have a fireplace or wood stove, perform the test once more. Leave the furnace off long enough for the flue to cool down. Then start a fire in the fireplace or wood stove and wait until the flames are burning well. Turn on the furnace and all the equipment as in the second draft test, wait a minute for the drafts to stabilize, and do the test as before.

If the smoke is not drawn up the draft hood, immediately open a window in the furnace room until you can install a combustion air supply. It would also be safest to use the fireplace or wood stove only with a nearby window or door open until you can provide fresh air from a permanent duct.

Even if the fireplace or wood stove passes the test, a separate combustion air supply is still needed for each wood-burning appliance.

Other warning signs. In addition to conducting the draft hood test, certain warning signs should definitely be heeded. These include frequent headaches and a burning feeling in the nose and eyes of the human occupants, and the gas flame in the furnace or heater burning yellow instead of blue. Following are other warning signs:

Carbon Monoxide Detector

The Energy Information Center strongly recommends installing a carbon monoxide (CO) detector in the home. The detector sounds an alarm after CO reaches a dangerous level. Make sure the detector has a UL listing. You should consider buying a detector with a low level digital display and a memory, in addition to a simple alarm. These features help diagnose a problem if one is discovered. CO detectors need to be tested regularly and cleaned as indicated in the manufacturer's instructions. If the unit operates off a battery, the detector should be tested weekly and the battery replaced at least once a year. For more information on CO and its health effects, call the Minnesota Department of Health at 612-215-0909.

Figure 2

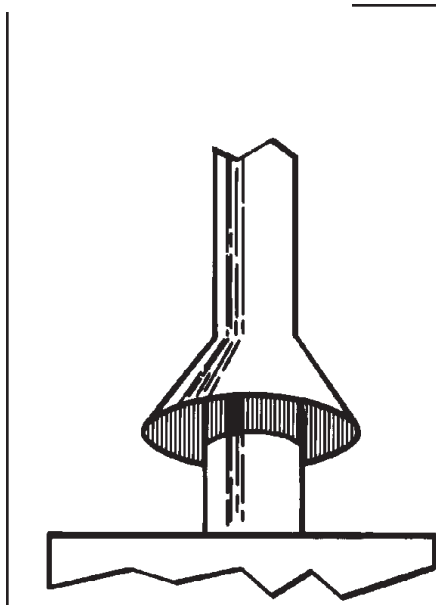

Figure 3

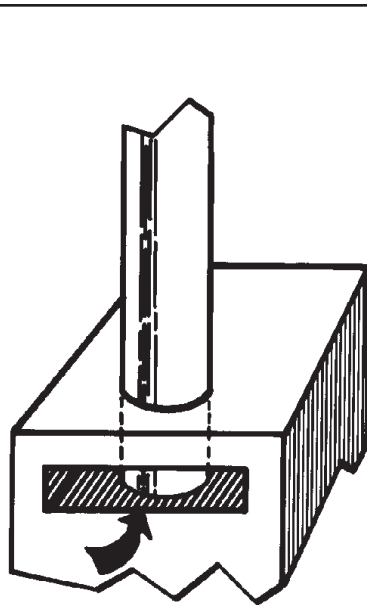
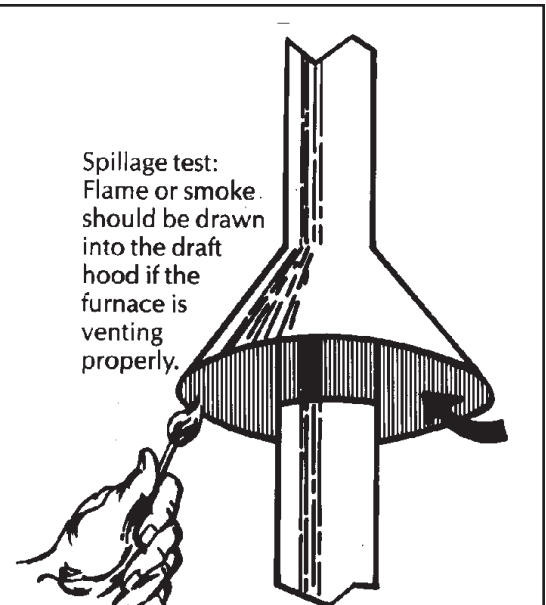

Figure 4



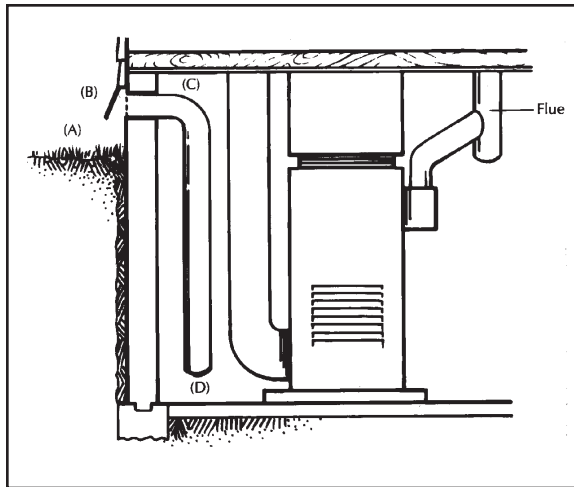

Figure 5

Oil furnace or heater. Black chimney smoke; fuel smell in the house; soot accumulation; outward leaking from doors or ports; popping, banging, rumbling, or delayed ignition.

Natural gas. Excessive moisture collecting on windows and walls, although this could be a symptom of other moisture problems and not necessarily of combustion air problems.

Wood. Smoking fire and improper drafting, even when the flue has warmed up.

These problems could also be caused by clogged combustion air intakes on the furnace, problems in the fuel-burning appliance, or an inadequate or damaged flue. If you notice any of these signs, you should have your system inspected by a professional heating contractor. Remember to have your furnace, water heater, and any other combustion appliance checked each year by a professional technician.

If you suspect a problem with combustion air, open doors and windows and air out the entire house. Then crack open a window in the furnace or fireplace room and leave it open until you can get professional advice and/or help to install an outside air duct to your furnace room, fireplace, or wood-burning stove.

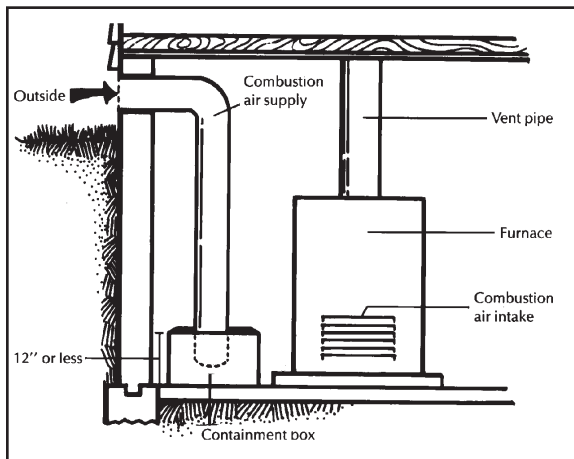

Figure 6

Outside combustion air supplies for the furnace

Whether or not you identify a problem, it is always wise to provide an outside combustion air supply.

Sealed combustion. Some new furnace, boiler, and water heater models use sealed combustion: that is, the combustion air is brought directly into a combustion chamber. Do not confuse sealed combustion with induced draft or forced draft equipment: these provide for mechanical exhaust, but not for bringing in outside combustion air. If you are in the market for a new furnace or water heater, we recommend you buy a sealed combustion or power-vented unit. A word of caution, however: even if you buy a sealed combustion furnace, you must still supply outside combustion air for the other fuel-burning appliances in your home.

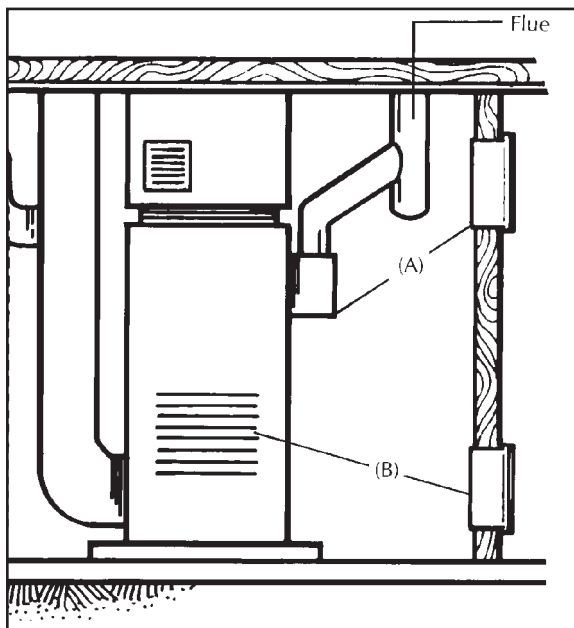

Figure 7.

Installing your own combustion air supply. If you do not have a sealed combustion furnace, you

can provide an outside combustion air supply yourself. Be sure to have your local building inspector check your work.

Two methods of installing an outside combustion air supply meet Minnesota building code requirements. The Energy Information Center recommends, however, that you use only one method, which is described below. The second method, which brings outside air into the return air duct, has two major drawbacks: it results in warm, humid air being brought into the home during the summer, increasing the load on the air conditioner and possibly causing summer moisture problems. In the winter, this same method may bring in excessive amounts of cold air, increasing air pressure within the home. This could result in moist indoor air being driven into walls and ceiling, potentially causing severe moisture problems in the house structure, including window and door frames.

The recommended method of supplying combustion air brings a duct from the outside to the vicinity of the furnace's combustion air inlet, which draws up the combustion air (Figure 5). When using this method, the state building code requires that the outside air intake (B) be one foot or higher than the outside ground level (A), that the intake be protected by a screen of 1/4-inch mesh, that the duct is at least the diameter of the flue (C), and that the supply outlet is not more than one foot above the floor (D).

To reduce cold air around the furnace, build a closed-bottom containment box out of sheet metal and drop the combustion air supply duct into it (Figure 6). The box or pail cannot be more than one foot high. Attach the pipe permanently to the container.

If the floor area of the furnace compartment is less than two times that of the floor area of the equipment, the building code requires that ventilation air be supplied to the confined space through two openings (Figure 7). The first opening must be placed above the draft hood opening and must be 1-square-inch for each 2000 Btus-per-hour capacity of the furnace (A). For example, an 80,000 Btu/hour furnace would require a ventilation air grille of 40 square inches. There must also be an opening of the same size (B) at a point below the combustion air inlet on the furnace.

Outside combustion air for fireplaces and wood stoves

Because fireplaces and wood stoves require large amounts of combustion air, it is an especially good idea to provide them with direct supplies of fresh air. It will make your house much safer. (see also *Wood Heat*)

With a fireplace, air from the outside should be brought through a duct that connects to an air vent directly in front of the fireplace grate. (Figure 8). The diameter of the duct will depend on the air needs of the fireplace.

The vent should be the same size as the duct so that it can be well sealed to prevent cold air leakage. The air vent should be easy to open and close so that when the fireplace is not in use it can be closed to prevent drafts.

You can install the duct through a basement window, the rim joist, or the basement wall as long as these locations are at least 12 inches above grade. If you bring the duct through the wall, seal around the hole. If the duct is placed through a window, cut a piece of board to fit in the window and around the duct, then weather-strip and caulk it, and insulate around it. (The window cannot be one that is used as an emergency exit.) You must install a 1/4-inch screen over the opening to keep out animals and debris.

Energy Savings

Bringing in combustion air from the outside will probably neither save nor cost energy. Energy savings occur when the vacuum pressure in the house is reduced, which reduces infiltration of cold air; when less warm room air is used for combustion; and when less warm air is pulled into the draft hood. Energy losses occur when more cold air, which has to be heated, is brought into the house to meet combustion air requirements. Combustion air and makeup air supplies are health and safety concerns and must be addressed. Buying an energy efficient, sealed combustion furnace and water heater provide energy savings as well as increased safety.

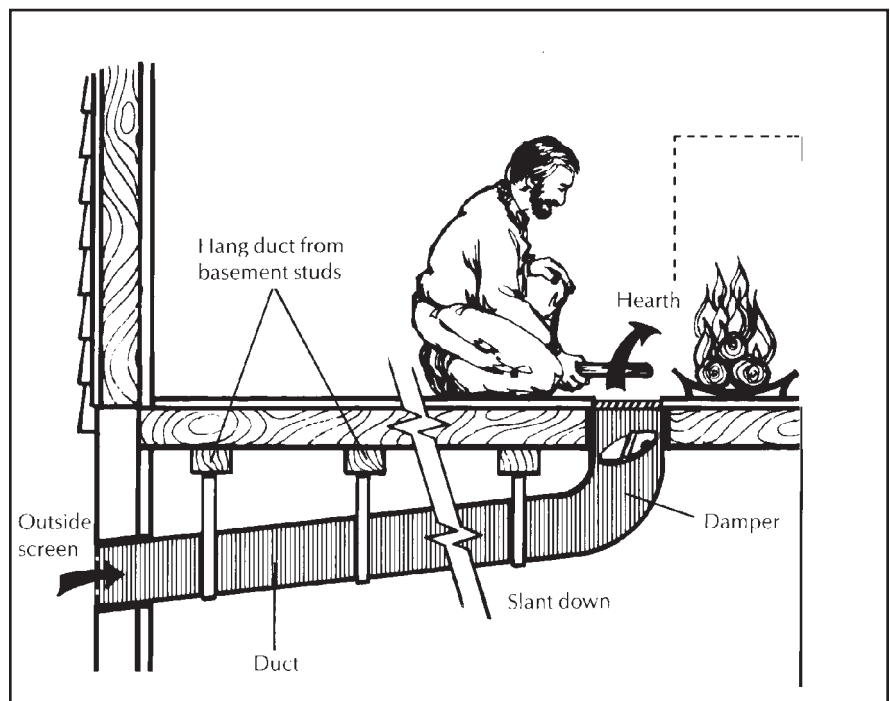

Figure 8.

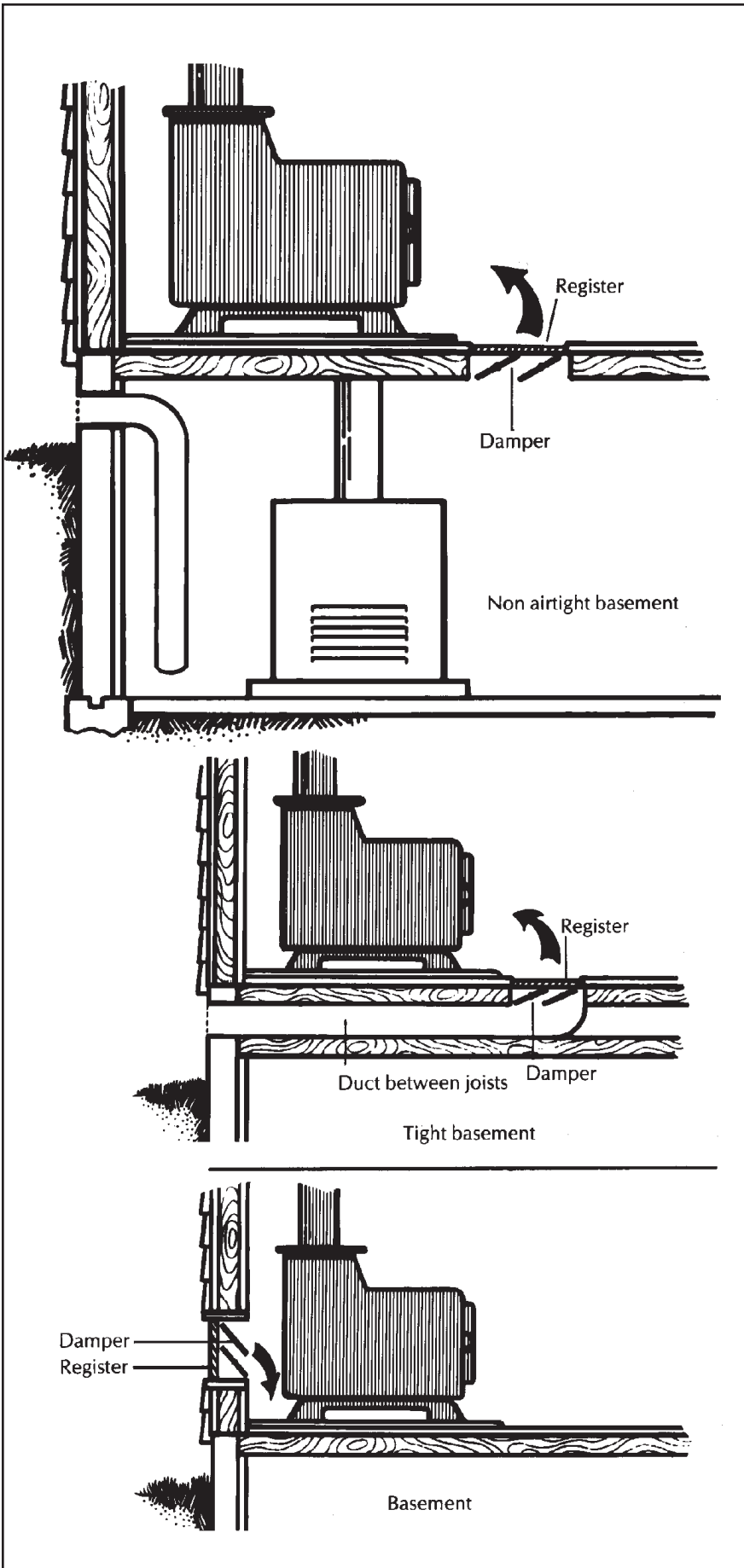

Figure 9.

A makeup air hood on the outside is strongly recommended.

The duct can be hung from the basement joists and should be tilted slightly downward toward the outside to prevent condensation from running down into the basement.

A tight-fitting damper – which is allowed in a wood system – is a good idea. You can use the damper to control the amount of draft when the fireplace is in use, and to help prevent cold air from leaking in when it's not in use.

Once the duct is in, take care to seal all the joints with high temperature metal tape and insulate it with noncombustible material. If it is possible, the air vent should be installed so that a glass door can be put on the fireplace. The vent should be between the glass door and the grate and will ensure that only outside air will be used for combustion.

Installing an outside combustion air supply to a wood stove is basically the same as for a fireplace (Figure 9). The simplest method is through an opening either under or in front of the stove that provides an air passage through the basement or crawl space. Air can also be brought directly from an outside wall of the house to the stove. Always install a tight damper to help control the draft and to prevent air from leaking in when the stove is not in use.

Combustion air should not be brought directly into the wood stove unless the stove is designed for it, and then only with a proper installation kit.

The Bottom Line

Always remember – any time you make changes in your home that could affect the air supply, you must ensure that there is adequate combustion air. These changes include tightening up the home to eliminate drafts and cold walls, remodeling or adding an addition to the home, buying a new combustion appliance (unless it has sealed combustion), or adding an exhaust fan. Consider installing an additional source of air to make up for any air exhausted elsewhere.

Important Points to Remember

- Make sure, by checking regularly, that the combustion air intake remains clear of snow, leaves, or other debris.
- Never supply combustion air from garages or other places where vehicles idle: they produce carbon monoxide and other contaminants.
- All fuel-burning equipment should be inspected regularly by a qualified service representative to keep it operating efficiently and venting properly. Inspect oil and gas equipment annually.
- Never use a gas range or oven for heating a room.
- If you have a new house that has an outside combustion air opening to your furnace, never block it.
- Never use a charcoal grill inside or near an air supply into the home. Burning charcoal, whether it's glowing red or turning to gray ashes, gives off large amounts of carbon monoxide.
- Wood stoves require a separate chimney. Never vent them into the existing heating system chimney.
- Never use unvented equipment indoors. This includes propane, gas and catalytic heaters, and gas lanterns.
- Unvented kerosene heaters should never be used indoors. Unvented kerosene space heaters are dangerous. The Energy Information Center does not recommend the use of any unvented heaters in any enclosed space. Exposure to emissions constitutes a health risk, even under relatively high ventilation conditions.
- Additions and remodeling change the air leakage characteristics of your home. Always test for combustion air during and after any remodeling project.